

寸法図

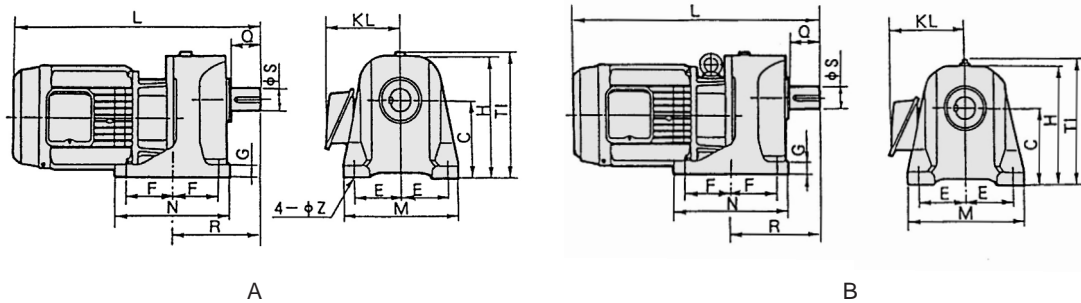

0.75 kW GAシリーズ寸法および価格 E種全閉外扇型、周波数50 / 60 / 60Hz 電圧：200/200/220V

型式	価格		概略減速比	図示	主要寸法(mm)											軸端		質量(kg)
	標準形	ブレーキ付			L	標準形	ブレーキ付	R	T ₁	C	F	E	N	M	KL	S	Q	
GA24-075- 3(B)	92,600	233,000	1/3	A	384	394	110	170	110	56	70	140	170	135	24	36	16	
GA24-075- 5(B)	77,400	146,000	1/5	A	374.8	364.8	110	170	110	56	70	140	170	135	24	36	17	
GA24-075-10(B)	81,700	188,000	1/10	A	374.8	364.8	110	170	110	56	70	140	170	135	24	36	17	
GA24-075-15(B)	82,300	152,000	1/15	A	374.8	364.8	110	170	110	56	70	140	170	135	24	36	17	
GA32-075-20(B)	87,700	156,000	1/20	A	405.8	415.8	152.6	195	125	72.5	90	180	220	135	32	58	22	
GA32-075-30(B)	89,900	158,000	1/30	A	405.8	415.8	152.6	195	125	72.5	90	180	220	135	32	58	22	
GA38-075-40(B)	99,300	168,000	1/40	B	426.5	436.5	167	252.5	135	85	90	210	220	135	38	58	30	
GA38-075-45(B)	108,000	172,000	1/45	B	426.5	436.5	167	252.5	135	85	90	210	220	135	38	58	30	
GA38-075-50(B)	118,000	185,000	1/50	B	448	458	167	244.5	135	85	90	210	220	135	38	58	38	
GA38-075-60(B)	126,000	195,000	1/60	B	448	458	167	244.5	135	85	90	210	220	135	38	58	38	
GA38-075-75(B)	130,000	198,000	1/75	B	448	458	167	244.5	135	85	90	210	220	135	38	58	38	
GA38-075-100(B)	136,000	204,000	1/100	B	448	458	167	244.5	135	85	90	210	220	135	38	58	38	
GA48-075-150(B)	228,000	298,000	1/150	B	506	516	208.5	258	160	100	110	245	275	135	48	82	52	
GA48-075-200(B)	239,000	309,000	1/200	B	506	516	208.5	258	160	100	110	245	275	135	48	82	52	

1.5 kW GAシリーズ寸法および価格 E種全閉外扇型、周波数50 / 60 / 60Hz 電圧：200/200/220V

型式	価格		概略減速比	図示	主要寸法(mm)											軸端		質量(kg)
	標準形	ブレーキ付			L	標準形	ブレーキ付	R	T ₁	C	F	E	N	M	KL	S	Q	
GA32-150- 3(B)	131,000	334,000	1/3	A	444	461.5	152.6	195	125	72.5	90	180	220	146	32	58	26	
GA32-150- 5(B)	95,200	181,000	1/5	A	438.8	456.3	152.6	195	125	72.5	90	180	220	146	32	58	27	
GA32-150-10(B)	101,000	188,000	1/10	A	438.8	456.3	152.6	195	125	72.5	90	180	220	146	32	58	28	
GA32-150-15(B)	102,000	190,000	1/15	A	438.8	456.3	152.6	195	125	72.5	90	180	220	146	32	58	28	
GA38-150-20(B)	108,000	197,000	1/20	B	458	475.5	167	218	135	85	90	210	220	146	38	58	34	
GA38-150-30(B)	111,000	198,000	1/30	B	458	475.5	167	218	135	85	90	210	220	146	38	58	34	
GA48-150-40(B)	126,000	210,000	1/40	B	503	520.5	208.5	292.5	160	100	110	245	275	146	48	82	46	
GA48-150-45(B)	136,000	254,000	1/45	B	503	520.5	208.5	292.5	160	100	110	245	275	146	48	82	46	
GA48-150-50(B)	164,000	274,000	1/50	B	538	555.5	208.5	258	160	100	110	245	275	146	48	82	57	
GA48-150-60(B)	168,000	286,000	1/60	B	538	555.5	208.5	258	160	100	110	245	275	146	48	82	57	
GA48-150-75(B)	171,000	287,000	1/75	B	538	555.5	208.5	258	160	100	110	245	275	146	48	82	57	
GA48-150-100(B)	184,000	300,000	1/100	B	538	555.5	208.5	258	160	100	110	245	275	146	48	82	57	
GA55-150-150(B)	313,000	428,000	1/150	B	576	593.5	238	294	180	125	132.5	305	320	146	55	82	67	
GA55-150-200(B)	352,000	468,000	1/200	B	576	593.5	238	294	180	125	132.5	305	320	146	55	82	67	

2.2 kW GAシリーズ寸法および価格 E種全閉外扇型、周波数50 / 60 / 60Hz 電圧：200/200/220V

型式	価格		概略減速比	図示	主要寸法(mm)											軸端		質量(kg)
	標準形	ブレーキ付			L	標準形	ブレーキ付	R	T ₁	C	F	E	N	M	KL	S	Q	
GA38-220- 3(B)	166,000	419,000	1/3	B	522	607	167	223.3	135	85	90	210	220	154	38	58	33	
GA38-220- 5(B)	118,000	228,000	1/5	B	522	607	167	224.5	135	85	90	210	220	154	38	58	34	
GA38-220-10(B)	126,000	236,000	1/10	B	522	607	167	224.5	135	85	90	210	220	154	38	58	35	
GA38-220-15(B)	128,000	240,000	1/15	B	522	607	167	224.5	135	85	90	210	220	154	38	58	35	
GA38-220-20(B)	136,000	250,000	1/20	B	522	607	167	224.5	135	85	90	210	220	154	38	58	35	
GA48-220-30(B)	139,000	259,000	1/30	B	566	651	208.5	258	160	100	110	245	275	154	48	82	48	
GA55-220-40(B)	155,000	279,000	1/40	B	583.5	668.5	238	328.5	180	125	132.5	305	320	154	55	82	64	
GA55-220-45(B)	172,000	302,000	1/45	B	583.5	668.5	238	328.5	180	125	132.5	305	320	154	55	82	64	
GA55-220-50(B)	203,000	326,000	1/50	B	634	719	238	294	180	125	132.5	305	320	154	55	82	72	
GA55-220-60(B)	234,000	358,000	1/60	B	634	719	238	294	180	125	132.5	305	320	154	55	82	72	
GA55-220-75(B)	238,000	361,000	1/75	B	634	719	238	294	180	125	132.5	305	320	154	55	82	72	
GA55-220-100(B)	259,000	384,000	1/100	B	634	719	238	294	180	125	132.5	305	320	154	55	82	72	
GA60-220-150(B)	393,000	517,000	1/150	B	673.5	758.5	277	321	195	140	145	336	350	154	60	105	90	
GA70-220-200(B)	438,000	561,000	1/200	B	719	804	315	363	225	177.5	167.5	415	395	154	70	105	103	



空圧・油圧・真空

直動システム・関連

ロボット・FA

制御・検出・計測

駆動・回転

軸受・素材・機械

動力伝達・伝動

搬送・運搬

ポンプ・送風機・粉体

工場設備・環境